

Creator Graphics Technology

Technical White Paper

January, 1999



© 1997, 1998, 1999 Sun Microsystems, Inc.—Printed in the United States of America.
901 San Antonio Road, Palo Alto, California 94303 U.S.A

RESTRICTED RIGHTS LEGEND: Use, duplication, or disclosure by the government is subject to restrictions as set forth in subparagraph (c)(1)(ii) of the Rights in Technical Data and Computer Software clause at DFARS 252.227-7013 and FAR 52.227-19.

The product described in this manual may be protected by one or more U.S. patents, foreign patents, or pending applications.

TRADEMARKS

Sun, Sun Microsystems, the Sun logo, Solaris, Sun Enterprise, OpenWindows, Solaris Operating Environment, Java, Java3D, TurboGX, “Write Once Run Anywhere”, VIS, Sun Elite3D, Ultra, XIL, and XGL are trademarks or registered trademarks of Sun Microsystems, Inc. UNIX is a registered trademark in the United States and other countries, exclusively licensed through X/Open Company, Ltd.

All SPARC trademarks are used under license and are trademarks or registered trademarks of SPARC International, Inc. in the United States and other countries. Products bearing SPARC trademarks are based upon an architecture developed by Sun Microsystems, Inc.

Display PostScript™ is a trademark or registered trademark of Adobe Systems, Incorporated in the United States and other countries. OpenStep™ is a trademark or registered trademark of NeXT Software, Incorporated. OpenGL® is a registered trademark of Silicon Graphics, Incorporated.

THIS PUBLICATION IS PROVIDED “AS IS” WITHOUT WARRANTY OF ANY KIND, EITHER EXPRESS OR IMPLIED, INCLUDING, BUT NOT LIMITED TO, THE IMPLIED WARRANTIES OF MERCHANTABILITY, FITNESS FOR A PARTICULAR PURPOSE, OR NON-INFRINGEMENT.

THIS PUBLICATION COULD INCLUDE TECHNICAL INACCURACIES OR TYPOGRAPHICAL ERRORS. CHANGES ARE PERIODICALLY ADDED TO THE INFORMATION HEREIN; THESE CHANGES WILL BE INCORPORATED IN NEW EDITIONS OF THE PUBLICATION. SUN MICROSYSTEMS, INC. MAY MAKE IMPROVEMENTS AND/OR CHANGES IN THE PRODUCT(S) AND/OR THE PROGRAM(S) DESCRIBED IN THIS PUBLICATION AT ANY TIME.



Please
Recycle



Adobe PostScript

Contents

1. Introduction	1
Increasing Graphical Complexity and Application Diversity ..	1
Creator Graphics from Sun	2
Supported Systems	4
2. Creator Graphics Overview	7
Creator and Creator3D Features	7
Creator Graphics System Overview	8
Creator Series 3 Graphics Systems	13
3. Creator Graphics Architecture	17
Creator Graphics Module	18
Frame Buffer Controller ASIC	19
3D-RAM — An Architecture for 3D Frame Buffers	21
The RAMDAC	25
UPA Memory Interconnect	30
UltraSPARC™ CPU	32
Creator Graphics Packaging	36
4. Software	37
Creator Graphics Software Interfaces	37
5. Summary	45
A. References	47



Introduction



Computer systems are being called upon to handle ever increasing visual complexity and larger amounts of graphical data in a wide range of formats. These visually charged computing environments are, in turn, presenting new challenges for the makers of graphics products — systems must handle larger workloads while preserving a high degree of interactivity to the user and they must be able to scale easily to handle larger workloads and more demanding applications.

Sun has responded to these significant challenges with a revolutionary approach to graphics system design known as Creator Graphics.

Increasing Graphical Complexity and Application Diversity

From spacecraft and airplanes, to automobiles, consumer products, and electronics, complex modern designs are enabled by sophisticated Computer Aided Design (CAD) applications. The technical and scientific professionals who execute and evaluate these designs perform extensive computer modeling, simulation, and analysis which require a combination of 2D and 3D graphics, imaging, and video technologies.

For less technical users, the Internet browser paradigm has emerged as a compelling way to deliver new kinds of graphical applications. Internet and intranet activities now routinely include viewing high resolution 2D images, navigating 3D data, and even interactively selecting and playing video titles.

For decades, the ability to simulate complex environments with powerful computers has been invaluable in training those destined to work with expensive equipment, in hazardous environments, or in life-critical circumstances. Technologies are needed that will shift the equation entirely, making sophisticated virtual portals, map displays, and visualization applications easier and more economical to implement.

Users demand computer systems which can accelerate the display and manipulation of a wide range of graphical data types. Systems must be affordable, and must scale gracefully to provide additional performance over time without large reinvestments in system hardware and application software. Traditional architectures are not meeting these demands.

Traditional Graphics Architectures

Unfortunately, many graphics subsystems are still designed as point products or as after market add-ons to existing computer systems. This loose integration often means that relatively powerful graphics engines are relegated to slow peripheral buses where poor throughput compromises performance. In addition, many graphics accelerators still provide only specialized functionality. Graphics devices which were designed to accelerate 3D vector graphics typically don't do well at accelerating pixel-oriented imaging or video applications and visa versa.

Creator Graphics from Sun

Now in their third generation, Sun's Creator Graphics systems provide an unparalleled level of acceleration and scalability for common graphics operations required by windowing, imaging, video, simulation, and 2D and 3D graphics applications.

Sun has long recognized that graphical performance cannot be considered independently from system design issues such as system throughput, processor speed, and memory bandwidth. As a result, Sun took a new approach with Creator Graphics by treating graphics as a fundamental part of the platform architecture, and as an integral part of the overall system design.

Highly Integrated

Creator Graphics replaces separate, specialized frame buffers with a single high performance, low cost architecture. The Creator Graphics architecture represents an innovative combination of modular design and provides very high levels of system integration.

Creator Graphics' design leverages powerful system functionality provided by high performance UltraSPARC™ processors, fast system memory, and high speed system interconnects. This approach maximizes performance while avoiding expensive duplication of resources.

Scalable Performance

With continually increasing graphics rendering and manipulation requirements, it is essential that graphics subsystems deliver scalable performance. Creator Graphics systems address scalability in a number of ways which provide transparent acceleration to existing applications.

As a function of their integrated design, Creator Graphics systems take advantage of high performance integer and floating point capabilities and the unique VIS™ instruction set of UltraSPARC processors for many graphics operations. As newer, faster versions of the UltraSPARC processor become available, graphics performance in Creator Graphics systems simply increases.

With the ability to configure up to four framebuffers in multiprocessing Sun Enterprise™ and HPC servers, Creator Graphics now support the creation of graphics systems that can deliver enormous amounts of computing and rendering performance, allowing the creation of large wall displays, virtual portals, and sophisticated simulation environments.

Broad Graphics Functionality Without Compromise

To meet broad user and application requirements and still deliver the desired capabilities economically, Sun's Creator Graphics family consists of two binary compatible accelerators, *Creator* and *Creator3D*. Together these subsystems provide the functionality and performance to meet the needs of a wide range of graphics applications:

- *Creator*

Creator is a single-buffered accelerator which accelerates applications like windowing, 2D graphics, imaging, and video. It's fast windowing and strong 2D and 3D vector performance make it ideal for applications like EDA, GIS, and graphic arts. Additionally, Creator's 24-bit window system performance rivals that of 8-bit systems, making Creator particularly well suited for photo retouching, medical imaging, and imaging GIS applications.

- *Creator3D*

Creator3D adds double-buffering capabilities and a Z-buffer — with no compromise in Creator functionality or performance. Creator3D is ideal for accelerating rendering of 3D solids and providing animation support through double buffering. Creator3D includes direct hardware acceleration for a broad set of 3D primitives, making it ideal for running applications like MCAD, MCAE, scientific visualization, and simulation.

Creator and Creator3D share the same system architecture and will both be referred to as Creator Graphics unless specifically noted.

Supported Systems

Creator Graphics represents a unified architectural approach to graphics across Sun's entire product line. A broad family of Creator Graphics systems is available to handle a wide range of applications. As shown in Table 1-1, configurations are available from single processor desktop workstations to powerful multiprocessor server systems with support for multiple monitors.

All Creator Graphics configurations are based on Sun's powerful UltraSPARC processors. These systems employ the Ultra Port Architecture (UPA) memory interconnect, a low-latency processor-memory technology capable of achieving very high levels of performance and scalability.

Creator Graphics systems run the Solaris Operating Environment™ software, Sun's industry-leading implementation of System V Release 4 (SVR4) of the UNIX® operating system, and enjoy full binary compatibility with other SPARC technology-based Sun systems. For more information on these systems, refer to their respective architecture white papers mentioned in the References section at the rear of the document.

System	Maximum Number of Processors	Maximum Number of Frame Buffers
Ultra™ 2 Creator/Creator3D	2	1 ¹
Ultra 10 Creator/Creator3D	1	1
Ultra 30 Creator/Creator3D	1	2
Ultra 60 Creator/Creator3D	2	2
Ultra 450 Creator/Creator3D	4	2
Sun Enterprise 3500 Creator3D	8	3 ²
Sun Enterprise 4500/5500 Creator3D	14	4 ³
Sun Enterprise 6500 Creator3D	30	4 ⁴

Table 1-1 Creator Graphics Systems

1. Creator Series 1 or Creator3D Series 2 only
2. Configuration with 3 framebuffers limits system to 4 CPUs
3. Configuration with 4 framebuffers limits system to 8 CPUs
4. Configuration with 4 framebuffers limits system to 24 CPUs

Creator Graphics Overview



Creator Graphics systems derive their extensive feature set and superior performance from a design that leverages advances in performance-critical technology coupled with intelligent system-level design.

The sections that follow describe Creator Graphics features and provide insights into Creator Graphics system design and performance characteristics. Chapter 3 explores the architecture of the Creator Graphics system in greater detail.

Creator and Creator3D Features

Unless specifically noted, this document describes the third generation Creator Graphics systems which are also known as Creator Graphics Series 3.

Creator Graphics Accelerator

Creator is a single-buffered accelerator which is ideal for imaging, video, multimedia, or 2D graphics applications. Creator systems provide fast 8- and 24-bit window system and imaging performance. Creator features include:

- *High performance, low cost, 24-bit true color standard*
- *Transparent acceleration for X11 and XIL™ graphics libraries*
- *Partial acceleration for XGL™ and OpenGL® 3D APIs*
- *Simultaneous 8-bit and 24-bit visual support*
- *Multiple hardware colormaps*
- *Adjustable gamma correction*

- *4-bit pseudocolor overlay support (non-destructive)*
- *High resolution (1280 x 1024 @76Hz non-interlaced)*
- *Stereo-ready (960 x 680 @112 Hz non-interlaced)*
- *DDC2B monitor serial communication with EDID support*

Creator3D Graphics Accelerator

Creator3D adds double-buffering and Z-buffer support for accelerating 3D solids and animation applications. Creator3D dramatically accelerates high-end 3D functionality like double buffering, triangle and quad rendering, and lighting and shading.

Creator3D provides 96 bit planes, including full 24-bit double-buffer planes required for smooth animation. A 28-bit Z-buffer enables hardware assisted hidden surface removal for dynamic rendering of 3D objects. Creator3D is fully compatible with Creator and does not compromise window system, 2D graphics, imaging, or video performance. Creator3D simply adds the acceleration and features required by 3D applications. Beyond the capabilities of Creator, Creator3D adds:

- *8-bit SOV-compliant pseudocolor overlay*
- *Transparent acceleration for 3D APIs (XGL, OpenGL, and Java 3D™ graphics APIs)*
- *3D solids, dynamic shading, rotation, and Z-buffered acceleration*
- *Full double-buffered 24-bit true color, 8-bit overlay, 28-bit Z-buffer, 4-bit stencil*
- *24-bit single-buffered high resolution support (1920x1200 with Sun 24" Monitor)*

Creator Graphics System Overview

It is impossible to describe how Creator Graphics achieves scalable high performance in such a wide range of graphics technologies without addressing the design of the overall system platform. The Creator Graphics architecture addresses two critical issues related to graphics design, *bandwidth* and *performance*.

Balanced System Throughput

In Creator Graphics systems, graphics data of several types must be able to move quickly between the processor, memory, and frame-buffer. Removing bottlenecks and providing scalability is key to providing performance in important areas.

- *24-bit Window System*

Creator Graphics provides 24-bit graphics at roughly the same performance as 8-bit graphics. This is a significant accomplishment considering that 3 to 4 times as much pixel data is involved in rendering 24-bit versus 8-bit data.

- *Imaging and Video*

In imaging and video applications, it is common for large amounts of data to be moved between system memory and the frame buffer/accelerator.

- *3D Graphics Commands*

3D graphics application performance can be hindered if the flow of graphics commands from the processor isn't sufficient to keep the graphics pipeline full.

Because the graphics subsystem was designed as a part of the overall system development process, engineers were able to implement special functionality to enhance bandwidth from the CPU and memory to the Creator Graphics module. Special CPU instructions combine with innovative transaction techniques to move large quantities of data at a high rate of speed across a fast packet-switched system interconnect.

Increased Graphics Performance

To design Creator Graphics, Sun engineers built on lessons learned with other architectures, enabling them to locate acceleration technologies in the system where they would most benefit graphics performance. This approach resulted in a highly-integrated, modular architecture that tightly couples the CPU, the system memory interconnect, and the frame buffer and graphics accelerator.

In Creator Graphics systems, graphics processing is balanced across the entire system to take advantage of all available resources. Table 2-1 lists the parts of the system which are responsible for *accelerating* different graphics operations.

Functionality	Responsible System Component
Window System and 2D Graphics	Creator Graphics Module
Imaging and Video	UltraSPARC (VIS Instruction Set), Creator Graphics Module
3D Graphics Pipeline	UltraSPARC (Floating Point Unit), Creator Graphics Module

Table 2-1 Components responsible for accelerating graphics in Creator systems

Window System and 2D Graphics

Window system and 2D graphics are specifically optimized for acceleration by the Creator Graphics module. To make this possible, Sun designers leveraged their considerable ASIC design experience from building successful 2D accelerators like the TurboGX™.

Working with window system and graphics software engineers, Sun’s Creator Graphics designers were able to implement key primitives like Bresenham lines, polygons fills, and text scrolling in ASIC technology to provide substantially higher window system performance.

In Creator Graphics systems, a special Frame Buffer Controller (FBC2) ASIC is principally responsible for execution of low-level 2D rendering operations.

Imaging and Video

There are several compelling reasons for moving imaging and video processing into the UltraSPARC processor in Creator Graphics systems:

- *Cache and MMU Integration*

By performing image processing in the CPU, the processor cache and memory management unit (MMU) can be used to great advantage. Since many image processing functions operate on neighboring pixels, the system cache can provide fast access to image data. The MMU can be utilized to access large images held in system memory (which are often striped and can exceed the cache) allowing them be operated on directly by the CPU in the same address space as other application data.

- *Scalable Performance*

When image processing functions are performed in the CPU, they can benefit from the scalability gained by adding faster or additional processors to the system. Many image processing functions are inherently parallel, and can benefit directly from the presence of multiple processors.

- *Rendering to Memory*

Most image processing is performed in a pipelined fashion, with the results of one operation serving as the input image for another operation, and the output of the pipeline being displayed to the screen. With Creator Graphics based systems, these intermediate images can be written to fast system memory, and higher precision can be used in calculating pixel values. When the final image is ready, it can be cropped, panned, zoomed, and copied via the fast block copy command to the screen.

- *VIS Instruction Set*

The UltraSPARC processor provides a special VIS Instruction Set which is primarily aimed at image and video processing. Some VIS instructions allow the CPU to directly access and operate on image (pixel) data with a high degree of parallelism. Other instructions provide facilities for formatting and moving data at very high rates of speed both within the CPU, and between the CPU and other system components.

VIS instructions are also used to accelerate 2D and 3D texture mapping, assist in managing and accessing large data sets such as those used in volume rendering, or for motion estimation used in video decompression. (For more information see discussion of UltraSPARC in chapter 3, and in the *UltraSPARC Processor Architecture White Paper*).

Video decompression is also aided by color conversion hardware in the Creator Graphics module. The YCbCr601 color space, is widely used in compressed digital video. Up to 30% of the processor cycles required for software decompression of MPEG-1 video are used to convert YCbCr601 color space information to RGB for display.

Providing this key component in hardware both increases software video decompression speeds and off-loads the CPU to perform other tasks.

3D Graphics Rendering Pipeline

On Creator3D systems, the 3D graphics pipeline is handled by *both* the UltraSPARC CPU and the Creator Graphics module, with the UltraSPARC CPU handling the front portion of the pipeline. Figure 2-1 contrasts the Creator3D graphics pipeline with that of Sun's highest performing Sun Elite3D™ graphics systems which employ specialized floating point hardware to accelerate the pipeline.

As the figure illustrates, the front portion of the 3D graphics rendering pipeline contains such floating point intensive operations as transformations, clip tests, face determination, lighting, perspective divide, and conversion to screen space coordinates.

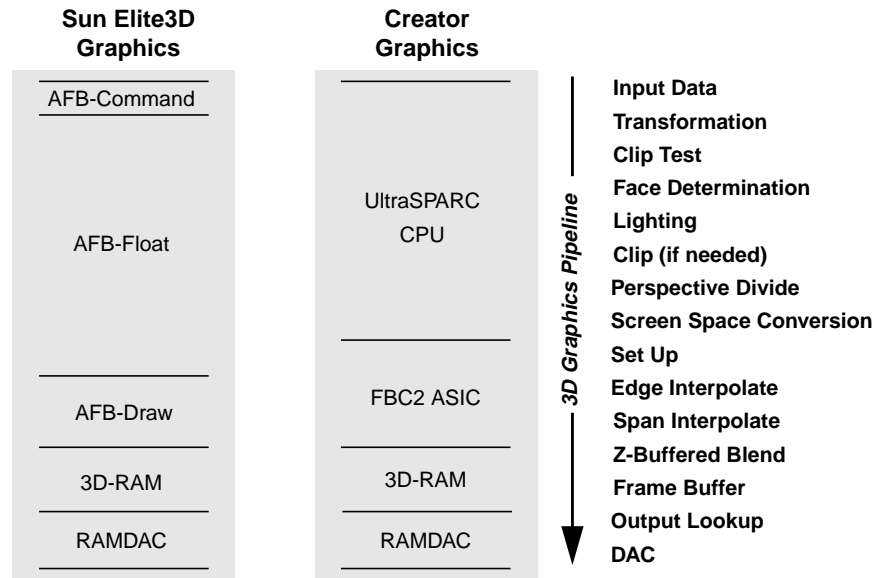

Figure 2-1 Pipeline differences between Sun's Elite3D and Creator Graphics systems

Only with recent advances in processor technology have general purpose processors been available with the necessary floating point processing power to implement a design like Creator Graphics. By using fast general purpose processors like UltraSPARC, it has finally become possible to build inexpensive systems that provide very respectable 3D performance.

Three main components on the Creator Graphics module accelerate the back end of the 3D graphics rendering pipeline. The Frame Buffer Controller ASIC (FBC2), 3D-RAM frame buffer technology, and the RAMDAC are discussed in greater depth in chapter 3.

Creator Series 3 Graphics Systems

Creator Series 3 Graphics modules incorporate a number of innovations which are key to demanding graphics applications.

- *Multiple Hardware Colormaps*

It is common in X11 for applications to consume more color resources than absolutely necessary. Several “color hog” applications running simultaneously can exhaust colormap resources on 8-bit color systems, resulting in colormap flashing. The initial availability of fast 24-bit color on Creator Graphics systems alleviated many colormap flashing issues. In special circumstances, however, colormap flashing was still possible between overlay and underlay planes.

Creator Series 3 Graphics modules contain four full hardware colormaps in place of the single colormap provided with previous systems. This abundance of colormap resources makes colormap flashing an extremely remote possibility, even with multiple applications vying for resources.

- *Full OpenGL Stencil Hardware Support*

OpenGL stenciling functions are most commonly used to mask out an irregularly shaped region of the screen but can also be used to perform interference checking, and end-capping. Interference checking determines if geometric objects to be drawn overlap or project into one another. End-capping works to place a “cap” over a hollow object that has been intersected by a clipping plane so as to make the object appear solid.

Creator3D Series 3 systems provide four full stencil planes and special acceleration to accelerate OpenGL stencil functions more than an order of magnitude over previous Creator3D systems.

- *Adjustable Gamma Correction*

Previous generations of Creator Graphics supported 24-bit linear color through a gamma ROM integrated into the RAMDAC. Because gamma was provided in a ROM, only fixed gamma correction was available. Fixed gamma occasionally caused applications built on other platforms with different gamma values to appear washed out or faded.

Creator Series 3 systems provide fully adjustable gamma correction. Rather than a gamma ROM, Series 3 Creator systems utilize one of the hardware color lookup tables (colormaps) to contain gamma tables, leaving three hardware colormaps for use as color look up tables for other applications. When no applications are active which require gamma correction, the four LUTs are available to perform as colormaps.

- *Server Overlay Visuals Support*

Server Overlay Visuals (SOV) is the *de facto* standard for the use of hardware overlays and pixel transparency for the X Window System. SOV-style overlays are frequently used by OpenGL programmers.

Though previous generations of Creator3D supported overlays, Series 3 Creator3D systems provide full SOV support with an 8-bit overlay plane. The overlay plane can provide transparency, up to 256 distinct opaque colors, and has access to the multiple hardware colormaps mentioned previously.

Scalable Graphics Performance

Sun has delivered on the promise of scalable graphics performance with Creator Graphics by paying careful attention to system throughput and a balanced design. This approach has allowed Creator Graphics systems to scale in performance as new, faster UltraSPARC processors have been made available.

Since the initial introduction of Creator Graphics systems, faster, UltraSPARC processors have been introduced at regular intervals, accelerating graphics systems performance. Even as UltraSPARC-II performance increases, 100% binary compatibility is always maintained. Details on the UltraSPARC-II processor are provided in chapter 3.

UltraSPARC-I and UltraSPARC-II Processors

Creator and Creator3D have identical performance characteristics for window system, 2D graphics, and imaging and video applications. Creator3D provides additional performance for 3D graphics and animation applications through its double-buffering and Z-buffer support.

Table 2-2 illustrates how Creator graphics has consistently scaled in performance along with the development of faster UltraSPARC processors. Note how the earlier Ultra™ 1 Creator3D running at 167 MHz compares against more recent systems equipped with successively faster UltraSPARC processors.

The information in Table 2-2 is provided as an example only and is current as of this writing. Graphics performance is constantly being improved as a result of software and hardware optimization.

Metric	Creator3D Series 1		Creator3D Series 3	
	Ultra 1 (167MHz UltraSPARC-I)	Ultra 10 (333 MHz UltraSPARC-IIi)	Ultra 60 (360 MHz UltraSPARC-II)	
Xmark93	17.6	31.5	33.0	
2D Vectors/second	1.59M	4.8 M	4.8 M	
3D Vectors/second	2.43M	3.7 M	3.7 M	
3D Triangles/second (25 pixel, chained, lit)	802K	1.3 M	1.3 M	
3D Quads (100pix, isolated, lit)	265K	464 K	468 K	
PLBwire93 (XGL)	132.8	233.0	248.3	
PLBsurf93 (XGL)	184.9	333.0	368.4	
CDRS-03 (OpenGL)	31.4	51.3	54.0	
DX-03 (OpenGL)	5.7	10.5	11.7	

Table 2-2 Creator Graphics scale with processor performance

Creator Graphics Architecture

Creator Graphics relies heavily on the use of a very high speed conduit between the system's CPU, memory, and graphics subsystem. The Ultra Port Architecture (UPA) system interconnect incorporates a high-speed packet-switched design which provides the necessary bandwidth to the Creator Graphics module from the memory subsystem and one or more UltraSPARC processors. Figure 3-1 illustrates a high-level block diagram for a typical Creator Graphics system.

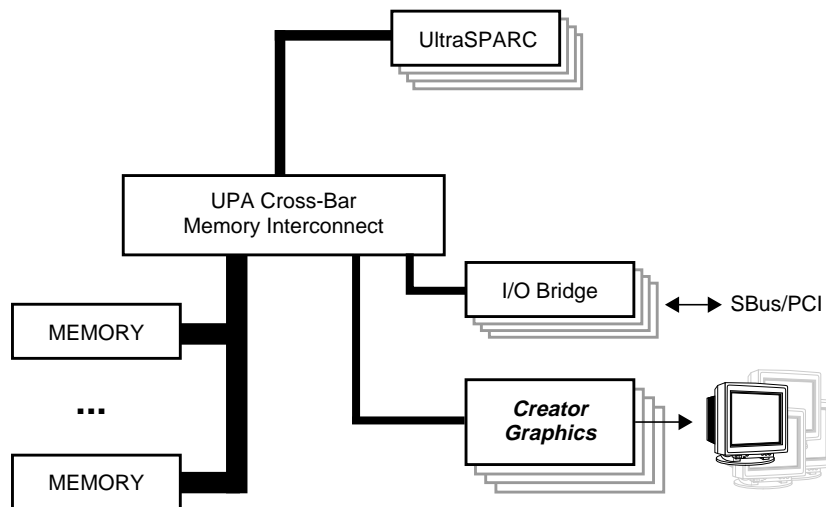

Figure 3-1 Creator Graphics system block diagram

Creator Graphics Module

The Creator Graphics module attaches directly to the UPA system interconnect via a 64-bit interface. This direct connection of the Creator Graphics module to the UPA interconnect, rather than via a peripheral bus, illustrates the importance of graphics to overall system design.

Creator and Creator3D share the same basic design. Creator3D differs from Creator only in that it contains more 3D-RAM frame buffer memory (15 MB versus 5 MB for Creator) to provide double-buffer and Z-buffer functionality. A slightly different RAMDAC packaging is also required by Creator3D to provide support for its additional features. Figure 3-2 illustrates a block-level view of the Creator Graphics module and highlights in gray differences between Creator and Creator3D. Note the wide, 64-bit data paths provided between the UPA interconnect and the Frame Buffer ASIC.

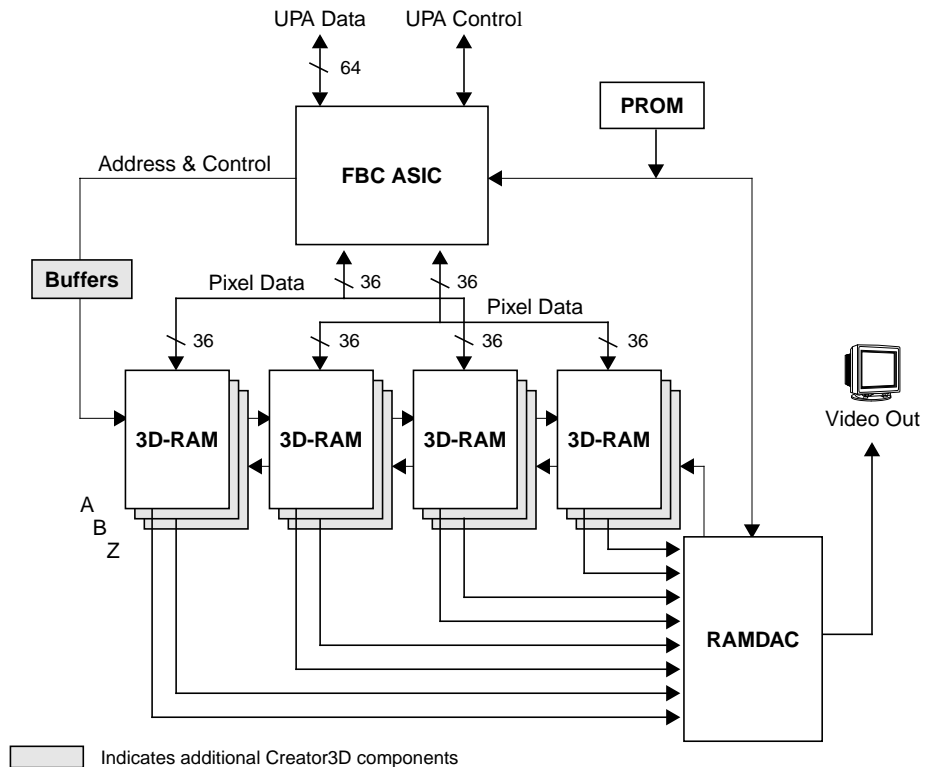

Figure 3-2 Combined Block diagram of Creator and Creator3D

The Creator Graphics module serves both as an accelerator and frame buffer and contains three key components — a *Frame Buffer Controller ASIC*, *3D-RAM*, and a *RAMDAC*. The Frame Buffer Controller ASIC (FBC2) provides an interface to the UPA memory interconnect and acceleration of graphics rendering. 3D-RAM provides an innovative new memory architecture for the frame buffer (discussed in more detail later). Finally, a highly-flexible dual-mode RAMDAC provides high-performance 8-bit and 24-bit color space management.

Frame Buffer Controller ASIC

The Frame Buffer Controller ASIC provides the back end of the 3D graphics rendering pipeline. Specifically, the FBC2 performs the set up, edge interpolation, and span interpolation functions (see Figure 2-1). It also performs pixel processing to accelerate high-end 3D functionality such as hidden surface removal, smooth shading, transparency, and antialiasing. Figure 3-3 illustrates how data flows through the FBC2 ASIC and the 3D-RAM frame buffer.

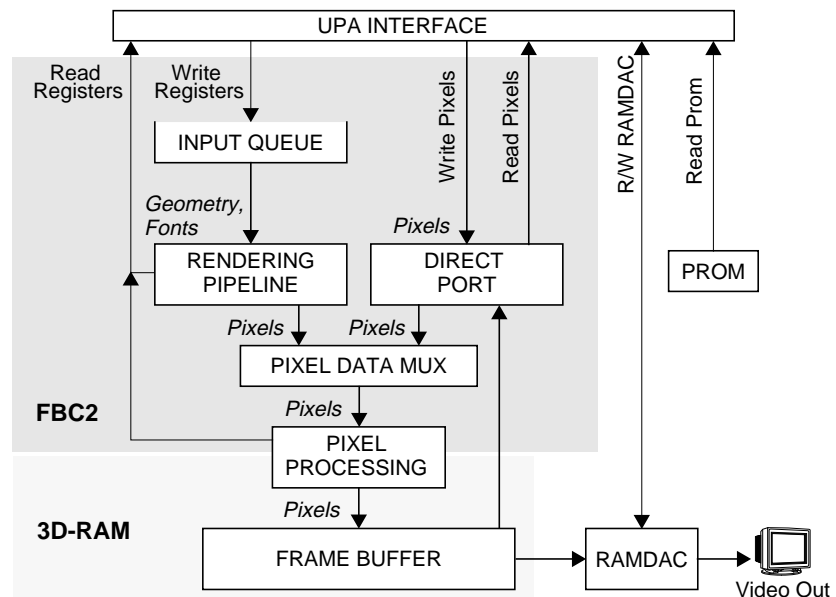

Figure 3-3 A logical view of the Creator Graphics subsystem

The FBC2 ASIC is implemented using LSI Logic's 0.35 micron G10 technology, and contains approximately 250K gates as well as 21 Kbits of RAM and 32 Kbits of ROM. The FBC2 is an extremely powerful processor capable of achieving 3.4 billion operations per second (BOPs) of peak data path processing power.

Rendering Pipeline

The *rendering pipeline* in the FBC2 is a one-way (write only) geometry and text pipeline, receiving geometric data in the form of vertices or fonts. Rendering pipeline primitives provided by the FBC2, and their attributes and usage are listed in Table 3-1.

Primitive	Attributes	Usage
Dot	Antialias, Alpha Blend	Graphics
Bresenham Lines	Pattern	Window System
Bresenham Polygons	Pattern	Window system
DDA Lines	Pattern, Antialias Depth Cue, Alpha Blend	Graphics
DDA Triangles	Shade, Z-buffer, Pattern, Depth Cue, Alpha Blend	Graphics
Rectangle Fill and Fast Fill	Fill, Clear	Window system, Imaging, Graphics
Font and Vertical Scroll	Text	Window System (text)

Table 3-1 Rendering Pipeline primitives, their attributes and usage

Once the rendering pipeline has completed processing of vertices and fonts, it outputs pixels to the pixel processing portion of the system where operations like Z-buffering, depth-cueing, alpha blending, and others are performed.

Direct Port

As an alternative to the rendering pipeline, the FBC2 provides a *direct port* which implements a two-way (read, write) high bandwidth pixel interface. Reads and writes can be performed as either single or block transfers.

Pixels sent through the direct port may receive additional pixel processing, or may be sent directly through to the frame buffer. Pixels coming from the rendering pipeline pass through the “Smart” frame buffer path of the pixel processor which performs accelerated pixel processing functions on the pixels.

If the system selects the “dumb” frame buffer, pixel processing operations are omitted and the frame buffer behaves like stateless memory. This option is useful for performing DMA directly to the frame buffer.

Pixel Processing (Smart Frame Buffer)

Using hardware in both the FBC2 and 3D-RAM, pixel processing in the Smart Frame Buffer can take place at extremely high rates. Example operations utilizing the Smart Frame Buffer include:

- *Constant Color, Alpha, Z Sources*
- *Area Patterns (transparent, opaque)*
- *Depth Cueing*
- *Alpha Blending (antialiasing, transparency)*
- *Viewport, Window ID, Stencil, Alpha Clipping*
- *Z-Buffering (hidden surface removal)*
- *Raster Operations, Buffer Selects, Plane Masks, Picking*

3D-RAM — An Architecture for 3D Frame Buffers

One of the traditional bottlenecks of 3D graphics hardware has been the rate at which pixels can be rendered into a frame buffer for Z-buffered rendering. Historically, the performance of hidden surface removal algorithms has been limited by the pixel fill rate of 2D projections of 3D primitives. The sections which follow discuss these limitations and how Creator Graphics’ innovative 3D-RAM overcomes them.

Challenges for Frame Buffer Design

Memory Technologies and Their Limitations

Most common computer memory technologies present serious trade-offs when used in the high-speed, low cost frame buffers of today’s volume systems. Dynamic Ram (DRAM) provides the best density and has the best understood

technology curve, but is generally too slow. Dual ported Video RAM (VRAM) offers improved bandwidth over DRAM, but VRAM performance has only improved by about 30 percent in the last five years. Static RAM (SRAM) provides fast cycle times but it is too expensive to implement economically in a desktop system. Exotic architectures, such as massive DRAM interleaving, are also available, but they are not practical for cost effective desktop systems.

Read-Modify-Write Operations

Another problem with conventional memory architectures is the number of *read-modify-write* transactions that result from 3D graphics applications. Read-modify-write operations should be avoided since they can take up to four times longer to complete than a pure write transaction.

Z-buffering, as required for 3D hidden surface removal, is the main operation that causes expensive read-modify-write transactions. The graphics application's Z coordinate data must traverse the pins of the chip twice — once to read out the old Z value, and a second time to write the new Z value if a new value is selected. Additionally, Window ID compares, stenciling, antialiasing, and blending operations cause expensive read-modify-write transactions.

3D-RAM

Working together, Sun Microsystems and Mitsubishi Electronics created breakthrough technology for implementing fast, inexpensive 3D frame buffers.

Mitsubishi developed a memory technology which incorporated DRAM and SRAM on a single chip while Sun developed a new concept for high-performance 3D frame buffer design. The result of this collaboration was announced at SIGGRAPH 1994 as FBRAM and is now known as 3D-RAM.

3D-RAM integrates DRAM and an SRAM cache on a single chip along with an on-chip arithmetic logic unit (see Figure 3-4). The result is a 10 Mbit part that handles 3D graphics ten times faster than conventional VRAM, at a lower system cost.

All of the 3D-RAM technology is kept within the constraints of the standard 16 Mbit DRAM fabrication process. This enables 3D-RAM to leverage the high volume, low-cost standard DRAM process. The die size has also been kept close to that of a 16-Mbit DRAM, allowing 3D-RAM to ride the same cost/learning curve as commodity DRAM.

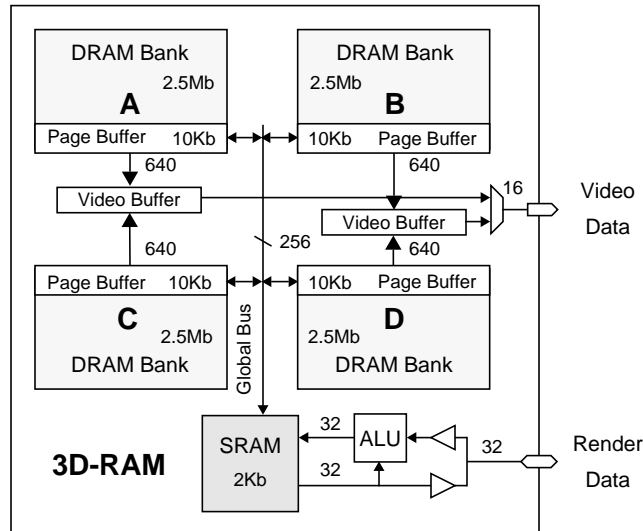

Figure 3-4 Internal block diagram of a single 3D-RAM chip

ALU Benefits Pixel Processing and Read-Modify-Write Operations

The arithmetic logic unit (ALU) in 3D-RAM provides three main functions:

- *Depth Unit — Performs Z-buffering comparisons*
- *Alpha Unit — Performs alpha blending, antialiasing, raster operations*
- *Stencil Unit — Computes OpenGL stencil functions*

Since the ALU was implemented directly on the 3D-RAM chip, the read-write-modify cycles caused by Z-buffering, alpha blending, and stenciling are performed completely inside the 3D-RAM. The external chip interface is converted from the traditional, less efficient, read-modify-write interface into a much faster write-only interface.

SRAM Cache and Caching Hierarchy

The 2-Kbit SRAM cache on the chip is multiported to yield enough data paths (3) and enough speed (12 nanosecond cycle) for efficient support of the 83 million pixel per second throughput inside the chip.

A two-level caching hierarchy was designed into the 3D-RAM chip to match the high performance of the ALU and the SRAM to the lower cost, higher density DRAM technology. Figure 3-5 illustrates the logical representation of a 3D-RAM 64 bank interleave. The caching system was specifically optimized for graphics. By using 3D-RAM memory controller technology, very high cache hit rates can be achieved.

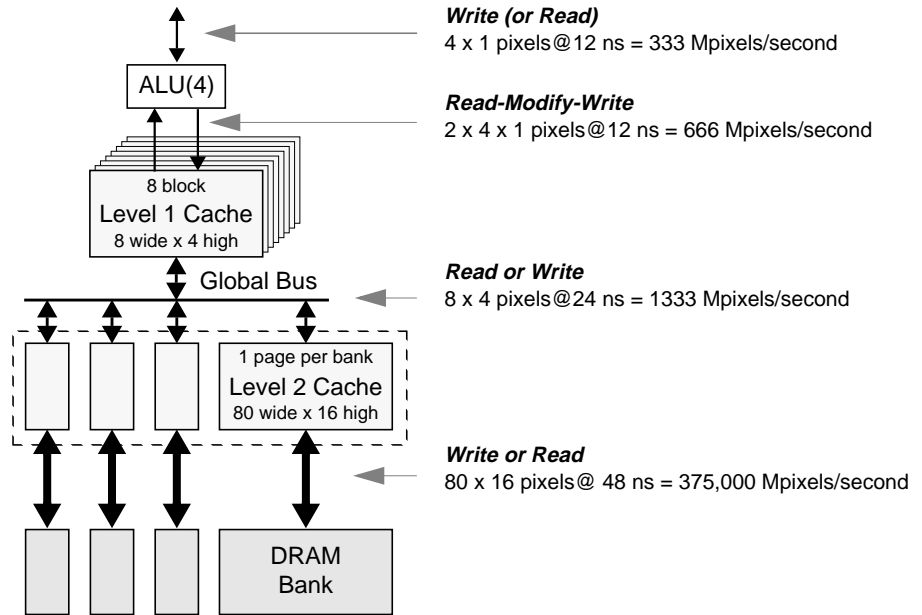

Figure 3-5 A logical representation of a Creator3D's four-way horizontally-interleaved frame buffer composed of twelve 3D-RAMs

Room to Grow

The 3D-RAM architecture is designed to easily scale to provide fast frame buffer memory for many years to come. Figure 3-6 illustrates the pixel fill rate needed to match anticipated triangle fill rate demands over the course of the next few years. The chart depicts minimum chip count 3D-RAM and VRAM based systems.

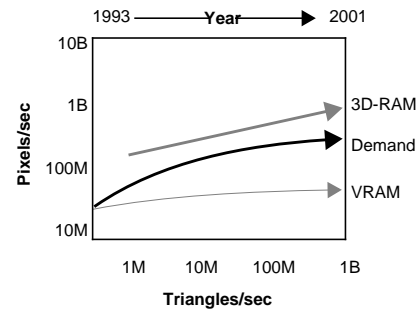

Figure 3-6 Estimated pixel fill rates needed to match anticipated triangle fill rates.

The RAMDAC

The RAMDAC converts digital data (in frame buffer memory) to the analog signals required to drive the CRT display. The term “RAM” refers to the color lookup table random access memory. The RAMDACs used in Creator and Creator3D systems are functionally identical — both use the same die but employ different packaging to accommodate the different signals they receive.

One of the principle design goals of the Creator Graphics system was to support all 8-bit and 24-bit applications and visuals simultaneously and with correct color. (For example, running an 8-bit ECAD application in one window, a 24-bit 3D gamma-corrected MCAD image in another window, and a live video feed in yet another.) This design goal meant providing color model selection and gamma correction on a per-window basis.

To address these requirements, Sun and Brooktree worked together to design the Bt497+ and Bt498+ RAMDACs for Creator and Creator3D Series 3 systems.

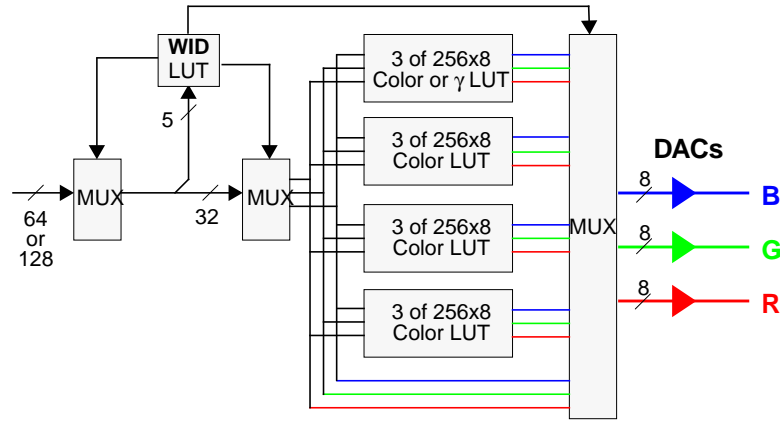

Figure 3-7 A functional diagram of the Bt497+ and Bt498+ RAMDACs

Multiple Pixel Paths

Multiple pixel paths are provided in the RAMDAC to enable applications to fine-tune their color selection mechanisms or avoid overhead. These alternative paths, consisting of *Color Lookup*, *Adjustable Gamma*, and *LUT Bypass*, enable very flexible colormap types with minimal overhead.

- *Color Lookup*

As shown in Figure 3-7, the RAMDACs used in Creator Series 3 systems feature four full hardware color lookup tables (previous generations of creator systems had a single LUT). Each color lookup table consists of three 256 x 8-bit RAMs. The Color LUTs receive pixels associated with direct color modes such as those from the X Window system. These tables are used for all 8- and 24-bit direct color pixels, while allowing for applications to change the LUT values.

The non-destructive 8-bit SOV overlay in Creator3D systems has full access to these colormaps allowing the default visual (and therefore, the window system) to run in the 8-bit overlay. By using this technique, 8-bit graphics or windows can be drawn over complex 24-bit imagery or graphics without damaging the underlying graphics.

- *Adjustable Gamma*

Previous generations of Creator Graphics provided a fixed gamma ROM to implement gamma correction. Creator Series 3 RAMDACs implement a more flexible solution by using one of the color lookup tables to hold the gamma table in the event that gamma correction is needed. This solution provides adjustable gamma correction that can be tuned to suit the needs of the application. In the event that one of the color LUTs is being used for gamma correction, three LUTs remain available for color lookup.

Gamma correction is needed for linear pixels used in synthetic images such as 3D graphics and ray tracing. The use of a gamma lookup table allows for the compensation required to match the logarithmic response of the CRT monitor. The gamma table is accessed via regular color model selection mechanisms and gamma is adjusted by using the `ffb_config` program.

- *Straight Through (LUT Bypass)*

The LUT Bypass path provides a means to send frame buffer data directly to the DACs in order to implement a nonlinear truecolor or greyscale color model. Because many 24-bit images (i.e. 24-bit video) are non-linear, this bypass mechanism helps avoid the overhead of passing data unnecessarily through the gamma and/or pixel color RAM LUTs.

Window ID Look-Up Table

The Window ID (WID) Look-Up Table provides a per-pixel ID for association with a particular window and pixel display mode (visual). This enables the RAMDAC to support displays that have multiple windows of mixed visual types. Pixel display modes supported by the WID Look-Up Table are provided in Table 3-2.

Integration

The RAMDACs employed by Creator Graphics systems integrate functionality that was previously spread throughout the system in other designs. This approach provides a higher level of integration and produces a considerable cost savings.

Pixel Display Modes	
8-bit PseudoColor (Overlay)	8-bit StaticGray (Nonlinear)
8-bit PseudoColor	8-bit StaticGray (Linear)
8-bit StaticColor	24-bit TrueColor (Nonlinear)
8-bit TrueColor	24-bit TrueColor (Linear, Gamma Corrected, Gamma = 2.22)
8-bit DirectColor	24-bit Directcolor (permits user-defined gamma)
8-bit GreyScale	

Table 3-2 Creator Graphics pixel display modes supported by the Window IB Look-up Table.

Hardware Cursor

The RAMDAC provides a dual-plane 64 x 64 pixel hardware cursor. The two cursor planes define three possible index values for the cursor color as well as transparency (i.e., allow the frame buffer contents to display). The cursor index values are applied to an overlay color lookup table in the RAMDAC.

Programmable Video Timing Generator

The RAMDAC includes a programmable video timing generator with a programmable resolution of up to 1280 x 1024 pixels (1920 x 1200 for Creator3D in single-buffered mode) to support Sun's current multisync monitor offerings.

The monitor connector contains a sense bus to identify the monitor connected to the Creator Graphics system. The monitor's ID is read by the RAMDAC and the appropriate timing is selected from the timing generator.

Table 3-3 lists the standard resolution and clock frequencies of the Creator Graphics systems. Included both Creator and Creator3D is a new PROM to better support PC resolutions and Sun's 21" monitor. Default resolutions for Creator and several of Sun's color monitors are also shown in the table.

Screen Resolution	Vertical Refresh Rate	Comments
1920 x 1200	70Hz	Sun 24" (HDTV) Monitor (Creator3D Series 2 or 3 in Single Buffered Mode)
1600 x 1200	75Hz	VESA
1280 x 1024	85Hz	Sun 19" and 21" Monitors, VESA
1280 x 1024	76Hz	Sony N2 20"
1280 x 1024	75Hz	VESA
1280 x 1024	67Hz	Sony P4 20", Sony P3 19"
1152 x 900	76Hz	Sony N2 17", Sony P4 17", Sony P3, 17"
1152 x 900	66Hz	Old BNC Monitors
1024 x 768	77Hz, 75Hz, 70Hz, 63Hz, 60Hz	VESA at 75Hz and 60Hz
1024 x 800	84Hz, 72Hz, 60Hz, 56Hz	na
960 x 680	112Hz Stereo 108Hz Stereo	na
800 x 600	75Hz	VESA
768 x 575	50Hz	PAL
640 x 480	60Hz	NTSC and VESA

Table 3-3 Supported monitors, resolutions, and display frequencies for Creator graphics systems

Stereo Support

Both Creator and Creator3D Graphics systems are stereo ready enabling users to view stereo images (Creator) or dynamic stereo 3D geometry (Creator3D) by adding the appropriate stereo viewing equipment.

A sync port is provided on the back of the Creator Graphics module which interfaces to stereo viewing equipment. First generation systems feature a mini-stereo connector to carry the sync signal while second generation systems utilize an 8-pin mini-DIN connector.

A compatible emitter and stereo glasses can be obtained from Stereographics Corporation (Part# ESUN: Emitter and Cable, and Part# CE2: Stereo Glasses)

UPA Memory Interconnect

Needing to balance the high computational and graphic performance of the Creator Graphics systems, Sun defined the requirements for a new system interconnect architecture. The principle design goals included:

- *Reduced memory latency and lower cost*
- *Optimized price/performance for uniprocessor and 2-4 way multiprocessor systems*
- *The need to reduce development time and cost by carefully identifying and implementing only those features which would appear in production systems.*

Engineers responded to these requirements with UPA, a new cache-coherent, processor-memory interconnect. As implemented in Creator Graphics systems, the principal advantages of the UPA over existing interconnects are significant:

- *Scalable bandwidth through support of multiple-bussed interconnects for data and addresses*
- *Higher bandwidth (three times faster than MBus)*
- *High performance graphics support with up to 120 MHz writes on the 64-bit UPA interconnect*
- *Better economy through centralized coherence and memory controller functions*

UPA is a packet-switched memory interconnect, and implements a buffered cross-bar switch for increased bandwidth and decreased latency. Packet-switched technology is usually only found on high-end servers and supercomputers. Performance gains of *six-to-one* have been realized by UPA over traditional circuit-switched buses which are more common on desktop workstations.

Though this performance is impressive, it should be noted that Creator Graphics systems do not currently use all of the available bandwidth present in the UPA design. This provides the opportunity for graphics performance to scale still higher with the use of faster or multiple UltraSPARC processors.

Figure 3-8 illustrates that within the UPA, different width paths are defined for different system components. The path to the processor(s) is 128 bits wide, while the memory data path is 256 bits wide. A 64-bit subset of UPA known as UPA64S is defined for communicating with the Creator Graphics module.

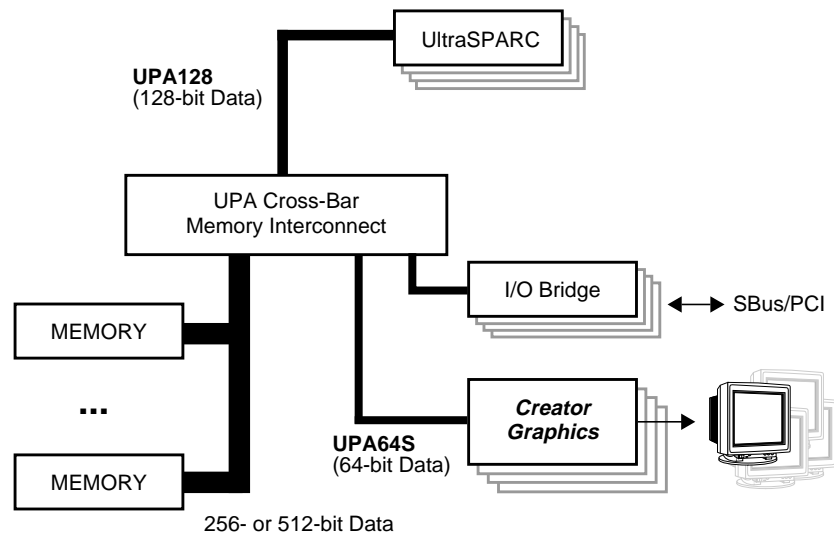

Figure 3-8 Creator Graphics block diagram

Running from 83 MHz to 120 MHz in Creator Graphics systems, and coupled with UltraSPARC's block copy instruction, the UPA is capable of moving large amounts of data at up to 1.9 GB per second. This bandwidth enables Creator graphics systems to update a 1 Megapixel window in real-time (e.g. a 1024 x 1024 8-bit image or a 640 x 486 24-bit image).

UPA64S

Ultra Creator and Creator3D systems implement UPA64S for communicating with the Creator Graphics module. UPA64S is a slave-only 64-bit subset of UPA that provides a simplified interconnect for graphics.

UPA64S has the following properties:

- *Open Boot PROM support*
- *Non-cached 1-16 byte writes and reads*
- *Non-cached block 64 byte writes and reads*

Creator Graphics implements a “write-mostly” architecture. Buffered writes can be sent to the frame buffer at a rate of 8 bytes per clock (up to 666 MB/second). Pipelined processing is done in the CPU, FBC2 ASIC, or 3D-RAM so that pixels simply “flow” toward the display at a very high rate.

UltraSPARC CPU

The UltraSPARC CPU was designed from the beginning to have a role in graphics. UltraSPARC is a 64-bit, SPARC V9 implementation which provides very high integer and floating point performance.

As previously discussed, this fast floating point performance allows the UltraSPARC CPU to accelerate the front end of the 3D graphics rendering pipeline that would otherwise require redundant, add-on graphics hardware at additional cost.

In addition, the UltraSPARC CPU differs from most other processors in that it is able to operate directly on pixel data. Finally, UltraSPARC includes additional instructions specifically designed for graphics called the *VIS Instruction Set*.

The UltraSPARC-II Processor

UltraSPARC-II represents a second-generation implementation of the UltraSPARC pipelined processor architecture. UltraSPARC-II retains complete upwards compatibility with the 32-bit SPARC™-V8 specification and the first-generation UltraSPARC-I, ensuring binary compatibility with existing applications. Both UltraSPARC-I and UltraSPARC-II provide 64-bit data and addressing and support a number of other features to improve operating system and application performance:

- *Nine stage pipeline; can issue up to 4 instructions per cycle*
- *Better cache management and greatly reduced memory latency*
- *On-chip cache 16K Data and 16K Instruction, with up to 16 MB external cache at higher bandwidths*
- *Integrated multi-processor support with low latency to shared data*
- *On-chip graphics and imaging support*
- *Implemented using 0.35 micron, 5-layer metal CMOS technology operating at 2.5 volts (UltraSPARC-II)*
- *Packaged using a 767-pin Land Gate Array (UltraSPARC-II)*
- *Support in UltraSPARC-II for higher clock rates than the UltraSPARC-I*

- *High performance both in SPECint95 (>12) and SPECfp95 (>18) at 300 Mhz (UltraSPARC-II in a uniprocessor configuration)*
- *Multiple SRAM modes allow more flexibility and economy in designing systems (UltraSPARC-II)*
- *Higher speed memory transfers (1.6 GB/sec)*
- *Implements the Ultra Port Architecture (UPA) Interconnect*
- *Support for the SPARC V9 prefetch instruction and outstanding memory requests (UltraSPARC-II)*

Graphics Unit

UltraSPARC processors provide a dedicated *Graphics Unit* (GRU) as a part of the floating point unit. The UltraSPARC processor incorporates a comprehensive set of graphics instructions that provide fast hardware support for 2D and 3D graphics, image manipulation and compression, and video and audio processing. 16-bit and 32-bit partitioned add, boolean, and compare functions are provided as are 8-bit and 16-bit partitioned multiplies. Single-cycle pixel distance, data alignment, packing and merge operations are all supported in the GRU.

VIS™ Instruction Set

The UltraSPARC processor was the first microprocessor to fully support advanced graphics and multimedia data manipulation. By introducing a comprehensive set of multimedia instructions, known as the VIS Instruction Set, the UltraSPARC processor provides extremely fast hardware support for 2D and 3D graphics, video and audio processing, and image manipulation. VIS instructions are grouped into the following areas:

- *Pixel format and conversion (expand, pack, merge)*
- *Image Processing (partitioned add, subtract, multiply, array addressing)*
- *Real-time video compression (motion estimation)*
- *Data transfer and animation speed-up (64-bit block load/store)*

The graphics unit in the UltraSPARC processor relies on the integer registers for addressing image data and the floating point registers for manipulating image data. This division of duty between the integer and floating point registers enables the processor to make use of all available internal registers, and hence maximize throughput.

Pixel information in the UltraSPARC processor can be represented as eight 8-bit, four 16-bit, or two 32-bit integer values. These values can be used to represent the color (RGB) and intensity information for a color image. For higher resolution images, like those used in medical or color imaging, 16-bit components can be used. Support is provided for both band-interleaved images, with the various color components stored together, and band-sequential images that have all of the values for one color component stored together.

Intermediate results for advanced image manipulation are stored as 16- or 32-bit, fixed-data values. These provide an intermediate format with enough precision and dynamic range for filtering and image computations on pixel values. The UltraSPARC processor has several single-cycle instructions specifically tailored for manipulating these 16- and 32-bit components.

The UltraSPARC processor also includes a variety of instructions that are essential for advanced image manipulation. For example, it supports a filtering operation for scaling, rotating, and smoothing images. The filtering operation processes four pixels at a time, giving the processor an *order of magnitude* performance advantage over other processors.

The UltraSPARC processor is also able to perform motion estimation in support of motion compensation, a technique used to code real-time video for compression. Motion estimation takes advantage of the minimal changes in the position of images from one frame to the next. The UltraSPARC processor performs hundreds of comparisons for a region of the image, searching for a motion value that minimizes the estimation error. The error is calculated by summing the differences for each pixel in the region between a reference frame and a newer frame.

The UltraSPARC processor minimizes this compute-intensive operation by operating on eight pixels at a time. The motion compensation process for eight pixels requires eight subtractions, eight absolute values, eight additions, a load of eight pixels, an align of eight pixels and one final addition. The processor performs this complex set of operations for eight pixels in just one clock compared to the minimum of 48 instructions and numerous clocks typically required by other processors. Since motion estimation is the dominant operation for compression, the processor's high throughput for this operation allows it to support compression for desktop video conferencing without the aid of external circuitry. Similar levels of instruction and clock-cycle savings can also be realized with other VIS instructions.

Unique block load/store commands in the processor allows it to execute 64-byte loads and stores directly into main memory. The block load/store commands avoid “cache pollution” by eliminating data allocation to external cache. With the resulting high copy bandwidth, the UltraSPARC processor can move images directly from main memory to the screen fast enough to eliminate image flicker.

Although VIS instructions were created to accelerate the manipulation of graphics data, it handles other types of partitioned data just as well. Other uses of VIS instructions include the processing of audio data and in encryption/decryption applications as well as for accelerating texture mapping operations.

Texture Mapping and VIS

Because texture mapping implies a potentially different color for each rendered pixel, it must be performed within the 3D pipeline. As a result, most vendors with pipelined 3D graphics accelerators have added dedicated texture storage memory to their accelerators in order to accelerate texture mapping.

Though dedicated texture memory can produce the best performance for direct display or small textures, it represents an expensive, limited resource which places distinct limits on the size and/or numbers of textures that can be represented. Though applications may run well if their texture(s) fit in the dedicated texture memory, the entire application may have to resort to a much slower software graphics pipeline if textures outstrip available memory on the accelerator. This kind of performance degradation is usually unacceptable for complex 3D applications.

Texture Mapping with Creator Graphics

Creator Graphics systems have no dedicated texture storage memory. Instead, textures are stored in inexpensive, general purpose system memory. This approach provides fast access to textures, and enables textures of virtually unlimited size to be used. Applications which use large or many textures such as 3D texture mapping in seismic or medical applications, as well as traditional 2D texture mapping work well on Creator3D.

Creator graphics systems provide a VIS technology-enabled rasterizer for performing texturing operations. Though slower than the hardware rasterization provided by the Creator3D graphics module, the VIS rasterizer is

considerably faster than the software rasterizer, and produces much more predictable application performance than systems with limited amounts of dedicated texture storage.

VIS instructions provide performance and cycle savings for a number of texture mapping operations. They are very useful for computing the various texture interpolation sampling methods used in texture mapping (e.g. bilinear interpolation, MIP mapped bilinear, MIP mapped trilinear and MIP map point linear interpolations). VIS instructions are also used to accelerate the calculation of texturing operations (modulate, blend, decal, etc.).

Lighting calculations for texturing utilize parallel 8 x 16 bit floating point multiplication, 16-bit floating point add, and 16-bit pack VIS instructions to operate on all of the color components of a pixel in parallel. Intermediate results are stored as a 16-bit floating point value for added precision.

Creator Graphics Packaging

The Creator and Creator3D graphics modules are implemented as a modular daughter card which plugs into the UPA system memory interconnect on Ultra workstation and Sun Enterprise server systems with an available UPA-64 port. Because Creator and Creator3D do represent different daughter cards, upgrading from a Creator to a Creator3D system does require swapping out the Creator Graphics card.

Creator Graphics Software Interfaces

Creator Graphics systems support all Solaris graphics and window system APIs, including OpenGL[®], Java 3D[™], XGL[™], XIL[™], and Display PostScript[™]. A large number of Sun and third-party graphics APIs are also supported, including IRIS GL, GKS, HOOPS, and PHIGS. Industry-standard X-extension libraries, such as Xlib and PEXlib, are available and are accelerated via the XGL and XIL foundation graphics libraries as shown in Figure 4-1.

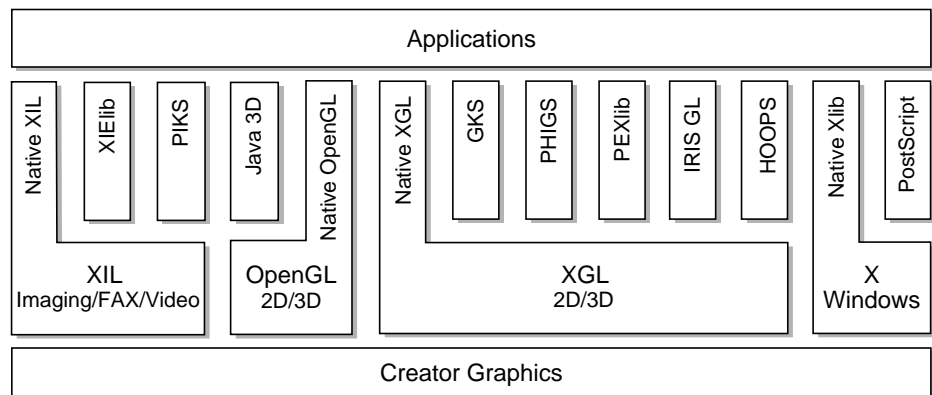

Figure 4-1 Solaris Foundation Graphics Libraries and layered interfaces

Because Creator Graphics platforms provide windowing, imaging, and geometry acceleration, they enhance the performance of all of the APIs mentioned above.

The sections that follow briefly describe the foundation graphics interfaces and the functions accelerated by the Creator Graphics products.

CDE and The OpenWindows™ Environment

Users have long pressed system vendors for a desktop environment that would have a consistent look and feel across all major UNIX® platforms. Sun has responded by co-packaging the Common Desktop Environment (CDE) with every copy of the Solaris Operating Environment software. Now users and developers have the choice of continuing to use the Sun OpenWindows environment, or the Motif-based industry standard, CDE.

Easy-to-use, CDE includes a variety of tools to simplify the management of applications and the desktop environment—a front panel to launch applications with a single click; a workspace manager to create multiple virtual desktops; a style manager to personalize the use of colors, backdrops, mouse and keyboard behavior, and startup characteristics. Other tools include text and icon editors, an image viewer, workgroup calendaring, file and print manager, and MIME-compatible electronic mail. CDE features drag-and-drop and cut-and-paste across OpenWindows, Motif, and OpenStep™ applications.

The OpenWindows environment features an MIT X11 Window System compliant server. Applications that use the X protocol, running both locally or remotely, will receive acceleration from Creator Graphics. The industry-standard Display PostScript environment (DPS) is provided within OpenWindows to support on-screen rendering of documents and images written with Adobe's PostScript page description language. Many window management functions have been optimized to take advantage of the Creator Graphics architecture, including the following functions:

- *Rectangle fills*
- *Line rendering*
- *Text rendering*
- *Vertical scrolling*
- *Get and put image*
- *Raster operations*

The XIL™ Imaging and Video Library

The XIL library is a foundation-level imaging interface providing the common functions required by many imaging and video applications. As a foundation software layer for imaging applications, the XIL API defines how imaging operations, such as display, image manipulation, and compression and decompression, are carried out. Functions available through the XIL API include:

- *Pan and zoom, scale*
- *Flips, transformations*
- *Raster rotation*
- *Sharpen, blur, convolution*
- *Monadic and dyadic image operations*
- *Blend, composite*

Three primary components make up the XIL library: a programming interface specification for basic imaging functionality, a high-performance implementation of the specification, and a standard hardware interface specification, which enables third-party hardware developers to readily support the XIL library and applications built upon it.

The XIL library is an object-oriented interface. As such, it hides the details of its implementation from the programmer. This enables the internals of the library to be extended without changing the interface in an incompatible way. C language bindings provide compatibility with other tools available under the Solaris Operating Environment software including a large number of software development products. Figure 4-1 illustrates the XIL library in relationship to other foundation-level interfaces.

Because many image processing functions lend themselves to parallelism, XIL is both “MT Safe”, and “MT Hot”. MT Safe implies that XIL can be used safely in programs which employ multithreading. XIL is MT hot in that it uses multithreading to parallelize selected image processing functions automatically.

The XIL imaging library utilizes a building-block approach to image operations through the use of simple operations known as *atoms*. More complex operations, called *molecules*, can be implemented using XIL to optimize applications to use low-level hardware features.

All XIL integer functions, whether they are 8-, 16-, or 32-bits, are accelerated by the UltraSPARC CPU and application of VIS instructions. Floating-point operations are handled by the UltraSPARC CPU's integrated floating-point processor.

The OpenGL[®] Geometry Library

The OpenGL graphics application programming interface is an industry-standard, vendor-neutral software interface which operates independently of operating and window system platforms. Based upon its proprietary predecessor, GL, OpenGL is an applications programming interface that provides 2D and 3D graphics functions, including modeling, transformations, color, lighting, and smooth shading, as well as advanced features such as texture mapping, NURBS, fog, alpha blending, and motion blur. The OpenGL API works in both immediate and non-editable display-list graphics modes.

The OpenGL Architecture Review Board is responsible for defining OpenGL's characteristics and features, as well as conformance testing, release approval, and specification definition. Like Sun's XGL graphics library, the OpenGL library is independent of any underlying window system, and display of rendered graphics occurs through either extensions to the graphics library or through direct window system calls.

The OpenGL library is targeted at developers creating interactive 3D applications for the enterprise, the intranet, and the Internet. These developers are generally affiliated with technical markets or in research facilities. Potential users include those in computer-aided design and manufacturing, global information systems, simulation, industrial design and modeling, entertainment, biochemistry, and petroleum exploration.

Sun[™] OpenGL[®] for Solaris[™] provides a complete solution for developing and deploying interactive 3D applications across Sun[™] workstations. It enables mainstream, industry-leading 3D graphics and visualization applications to be deployed on Sun's Ultra Creator3D and Sun Elite3D[™] systems at a compelling price/performance ratio.

The widespread multivendor availability of OpenGL libraries ensures source code portability of 3D graphics clients. Open GL 1.1.2 for Solaris is a compliant implementation of OpenGL 1.1 from the OpenGL Architecture Review Board and is, therefore, source code compatible with other compliant OpenGL applications. Most existing OpenGL applications will only need to be recompiled in order to run under OpenGL 1.1.2 for Solaris.

OpenGL 1.1.2 for Solaris provides an implementation of OpenGL that incorporates hardware acceleration when used in conjunction with Creator graphics:

- *Transformations - 2D (3x2) and 3D (4x4)*
- *Geometry Attributes - color, line type, fill pattern and textures, etc.*
- *Lighting and Shading - flat and Gouraud as well as up to 32 light sources (positional, directional, spot, and ambient)*
- *Non-Uniform Rational B-Splines (NURBS)*
- *Transparency - screen-door and alpha blended transparency*
- *Anti-Aliasing*
- *Depth Cueing - linear and scaled*
- *Texture Mapping - 2D texturing of 3D surfaces (accelerated using VIS)*

Specific OpenGL 1.1 extensions supported by Sun include:

- *3D texture mapping*
- *ABGR reverse-order color format*
- *Texture color table*
- *SGI color table*
- *Sun geometry compression*
- *Rescale normal*

Fully integrated with the Solaris Operating Environment software, OpenGL 1.1.2 allows developers to take advantage of its advanced features, including multithreading and full support for 64-bit computing. OpenGL 1.1.2 also includes new imaging extensions to allow developers access to both graphics and imaging functionality within the same application and other enhancements to support increased performance and functionality. Solaris OpenGL can run with Common Desktop Environments (CDE) or OpenWindows environments. A defined common extension to the X Window System allows OpenGL client to run across distributed heterogeneous networks.

For more information about Sun's implementation of OpenGL, refer to the document entitled *Solaris OpenGL 1.1 Implementation and Performance Guide*.

The Java 3D™ Library

The Java 3D API extends the Java™ technology vision of “Write Once, Run Anywhere™” to interactive 3D graphics. A part of the Java Media set of APIs, the Java 3D API is an application programming interface used for writing stand-alone three-dimensional graphics applications or Web-based 3D applets.

The Java 3D API gives developers high level constructs for creating and manipulating 3D geometry and tools for constructing the structures used in rendering that geometry. With Java 3D API constructs, application developers can describe very large virtual worlds, which, in turn, are efficiently rendered by Sun framebuffer products.

An application or applet written using the Java 3D API can render images to a broad range of display devices including flat screen displays, portals/caves, and head-mounted displays all without modification to the code. The same application or applet, (once again without modification) can render stereoscopic views and can take advantage of the input from a head-tracker to control the rendered view.

As shown in Figure 4-1, the Java 3D API is built on top of the OpenGL foundation library for Solaris Operating Environment platforms. To optimize rendering, implementations are layered to take advantage of the native, low-level API that is available on a given system. In particular, Java 3D implementations that utilize OpenGL, Direct3D, and QuickDraw3D are available. Rendering is accelerated across the same wide range of systems that are supported by these lower-level APIs.

The Java 3D specification is the result of a joint collaboration between Silicon Graphics, Inc., Intel Corporation, Apple Computer, Inc., and Sun Microsystems, Inc. All had advanced, retained mode APIs under active internal development, and were looking at developing a single, compatible, cross-platform API in the Java programming language.

For more information on the Java 3D API, see the *Java 3D API White Paper* and the *Java 3D API Specification*.

The XGL™ Geometry Library

The XGL library is a Solaris foundation geometry library providing functionality and performance required by applications requiring geometry manipulation and display. The XGL library provides for optimization of 2D and 3D rendering, including high-quality lighting and shading, and advanced primitives (such as NURBS and meshes, texture mapping, antialiasing, and transparency), and a flexible geometry pipeline. The XGL library includes sophisticated state-of-the-art features, such as dynamic tessellation of NURBS surfaces, as well as flexible pipelines for lighting and transformation.

Creator Graphics systems provide acceleration for many XGL library functions:

- *Transformations - 2D (3x2) and 3D (4x4)*
- *Geometry Attributes - color, line type, fill pattern and textures, etc.*
- *Lighting and Shading - flat and Gouraud as well as up to 32 light sources (positional, directional, spot, and ambient)*
- *Non-Uniform Rational B-Splines (NURBS)*
- *Transparency - screen-door and alpha blended transparency*
- *Anti-Aliasing*
- *Depth Cueing - linear and scaled*
- *Texture Mapping - 2D texturing of 3D surfaces (accelerated using VIS)*

Like the XIL library, the XGL library has an object-oriented interface that hides the low-level details of implementation from the application developer. As such, it is architected so that it may evolve as an interface, permitting new algorithms to be implemented within the XGL library without incompatibly changing the application program interface bindings.

Summary



Driven by both the increasing sophistication of applications and users, as well as by broad trends in hardware performance and cost reduction, graphics have become an integral part of technical computing today. Despite these advances, most graphics subsystems are an afterthought. Their design, limited integration, and emphasis on performing specific subsets of graphics functionality reveal that they were designed without considering overall system architecture.

Sun Microsystems is the established volume leader in graphics systems shipments for virtually every market. From ECAD, MCAD, and GIS, to UNIX based publishing and graphics arts, Sun systems represent the largest single vendor platform in use today. Sun has gained leadership in these markets because of its single-minded focus on platform integration, meeting its intended goal of providing the best price/performance desktop and server solutions available. Sun's revolutionary Creator Graphics based systems are no exception.

Designed as part of the overall UPA system architecture, Creator Graphics incorporates the best features of Sun's previous accelerators and frame buffers, at a fraction of the cost and at almost twice the performance. Highly integrated, and high performance, Creator Graphics demonstrates Sun's leadership in, and commitment to, technical users and their applications.

References



Sun Microsystems Computer Company posts product information in the form of data sheets, specifications, and white papers on its Internet World Wide Web Home page at: <http://www.sun.com>.

Look for the these and other Sun technology white papers:

FBRAM: A New Form of Memory Optimized for 3D Graphics, Proceedings of the ACM, SIGGRAPH '94.

XGL Geometry Graphics for Solaris, White Paper, SunSoft Inc.

XIL Imaging for Solaris, White Paper, SunSoft Inc.

The SPARCstation 5S24 Architecture, White Paper, Sun Microsystems Computer Company

The Ultra 2 Architecture, White Paper, Sun Microsystems Computer Company

The Ultra 5 and Ultra 10 Architecture, White Paper, Sun Microsystems Computer Company, January 1998

The Ultra 30 Architecture, White Paper, Sun Microsystems Computer Company, July 1997

The Ultra 60 Architecture, White Paper, Sun Microsystems Computer Company, January 1998



Ultra Enterprise X500 Server Family: Architecture and Implementation, White Paper, Sun Microsystems

Elite3D Graphics, White Paper, Sun Microsystems Computer Company, January 1998

Advanced Graphics on Sun: An Introduction to Texture Mapping, White Paper, Sun Microsystems Computer Company, July 1997



Sun Microsystems
901 San Antonio Road
Palo Alto, CA 94303-4900 USA
650-960-1300
FAX 650-969-9131
<http://www.sun.com>

Sales Offices

Argentina: +54-1-317-5600
Australia: +61-2-9844-5000
Austria: +43-1-60563-0
Belgium: +32-2-716 79 1 1
Brazil: +55-1 1-5181-8988
Canada: +905-477-6745
Chile: +56-2-638-6364
Colombia: +571-629-2323
Commonwealth of Independent States:
+7-502-935-841 1
Czech Republic: +420-2-33 00 93 1 1
Denmark: +45 4556 5000
Estonia: +372-6-308-900
Finland: +358-9-525-561
France: +33-01-30-67-50-00
Germany: +49-89-46008-0
Greece: +30-1-6188130
Hungary: +36-1-202-4415
Iceland: +354-563-3010
India: +91-80-5599595
Ireland: +353-1-8055-666
Israel: +972-9-9513465
Italy: +39-039-60551
Japan: +81-3-5717-5000
Kazakhstan: +7-3272-466774
Korea: +822-3469-01 14
Latvia: +371-755-1 1-33
Lithuania: +370-729-8468
Luxembourg: +352-49 1 1 33 1
Malaysia: +603-264-9988
Mexico: +52-5-258-6100
The Netherlands: +31-33-450-1234
New Zealand: +64-4-499-2344
Norway: +47-2202-3900
People's Republic of China:
Beijing: +86-10-6803-5588
Chengdu: +86-28-619-9333
Guangzhou: +86-20-8777-9913
Shanghai: +86-21-6466-1228
Hong Kong: +852-2802-4188
Poland: +48-22-8747800
Portugal: +351-1-412-7710
Russia: +7-502-935-841 1
Singapore: +65-438-1888
Slovak Republic: +421-7-522 94 85
South Africa: +271 1-805-4305
Spain: +34-91-596-9900
Sweden: +46-8-623-90-00
Switzerland: +41-1-825-71 11
Taiwan: +886-2-2514-0567
Thailand: +662-636-1555
Turkey: +90-212-236 3300
United Arab Emirates: +971-4-366-333
United Kingdom: +44-1-276-20444
United States: +1-800-821-4643
Venezuela: +58-2-905-3800
Worldwide Headquarters: 650-960-1300